

Amplifier Comparator and Knock Pulse generator

Long Pulse blocker

Reset logic and timer

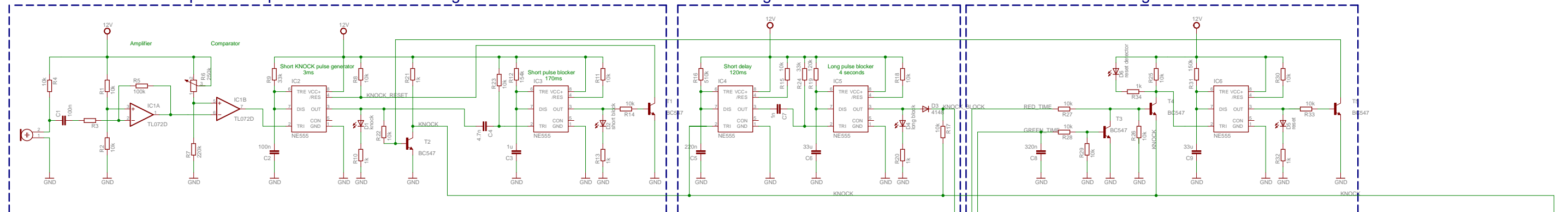

1st timing stage

2nd timing stage

3rd timing stage

4th timing stage

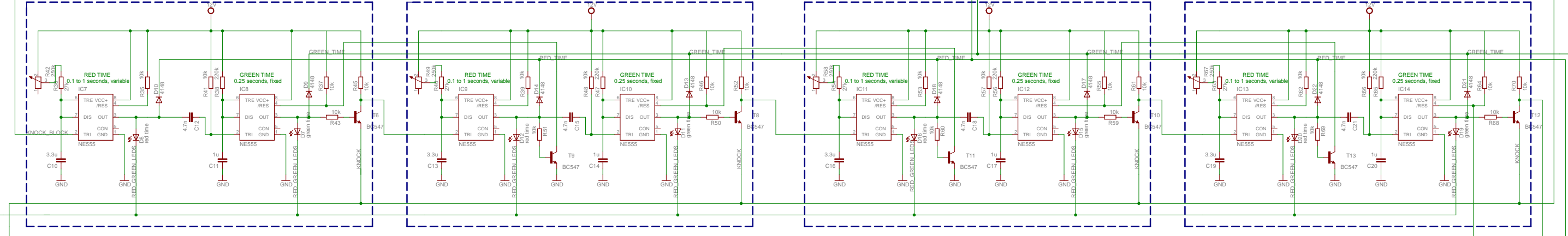

5th timing stage

6th timing stage

7th timing stage

Door Open Timer and Relay

